

Elevation Innovation Inc.

TITLE: INTELL-LIFT PRO 125 GAL
DOORS - SAME SIDE WITH GATE
24"W x 24"H x 24"H 125 lb. Capacity

REVISIONS

REV	DESCRIPTION	DATE	BY

STOPS: 2 IN-LINE OPP.

OPENINGS: 2 @ LOWER, UPPER.

TRAVEL: I.B.O.

<input checked="" type="checkbox"/> SAME SIDE	<input checked="" type="checkbox"/> DR/WALL CONSTRUCTION
<input type="checkbox"/> SLIDE-UP	<input type="checkbox"/> MASONRY CONSTRUCTION
<input type="checkbox"/> FLOOR LOADING	<input type="checkbox"/> PLAIN STEEL - PRIMED
<input type="checkbox"/> STAINLESS SILLS	<input type="checkbox"/> STAINLESS STEEL - #4
<input type="checkbox"/> FUSIBLE LINK	<input type="checkbox"/> COUNTER LOADING
<input checked="" type="checkbox"/> 1 1/2 HR U/L "B" LABEL	
<input checked="" type="checkbox"/> EMERGENCY RELEASE	
<input checked="" type="checkbox"/> NON-PLUGGABLE INTERLOCK	
<input checked="" type="checkbox"/> HG-1 SINGLE CONTACT DOOR LOCK & CONTACT NEMA 1	
<input checked="" type="checkbox"/> HG-2 DOUBLE CONTACT INTERLOCK NEMA 1	

JAMB MOUNTED 24V PUSHBUTTON STATIONS:
 NON-ILLUMINATED ILLUMINATED
 BUTTONS: UP DOWN 1 2 3
 LIGHTS: CAR HERE IN USE
 HEADER MOUNTED 24V CAR ARRIVAL LIGHTS

CAR GATE	ALUMINUM		
ACCESS DOOR	SLIDE-UP	BY: EII	
	PLAIN STEEL		
	1 1/2 HR U/L "B"	NONE / BY OTHERS	

HOISTWAY TO BE BUILT BEFORE DUMBWATER IS INSTALLED EXCEPT THE WALLS ARE TO BE OMITTED WHERE HOISTWAY DOORS OCCUR UNTIL THE DUMBWATER IS INSTALLED & HOISTWAY DOORS ARE SET IN PLACE

POWER SUPPLY: A LOCKABLE FUSED DISCONNECT MUST BE PROVIDED IN ACCORDANCE WITH LOCAL ELECTRICAL CODES. THE SUPPLY MUST BE A 115V, 20A DEDICATED CIRCUIT.
 DOORS: DOORS MUST MEET LOCAL FIRE CODE. INTERLOCK DEVICES ARE PROVIDED AND MUST BE MOUNTED TO DOORS AS DIRECTED IN THE INSTALLATION GUIDE.

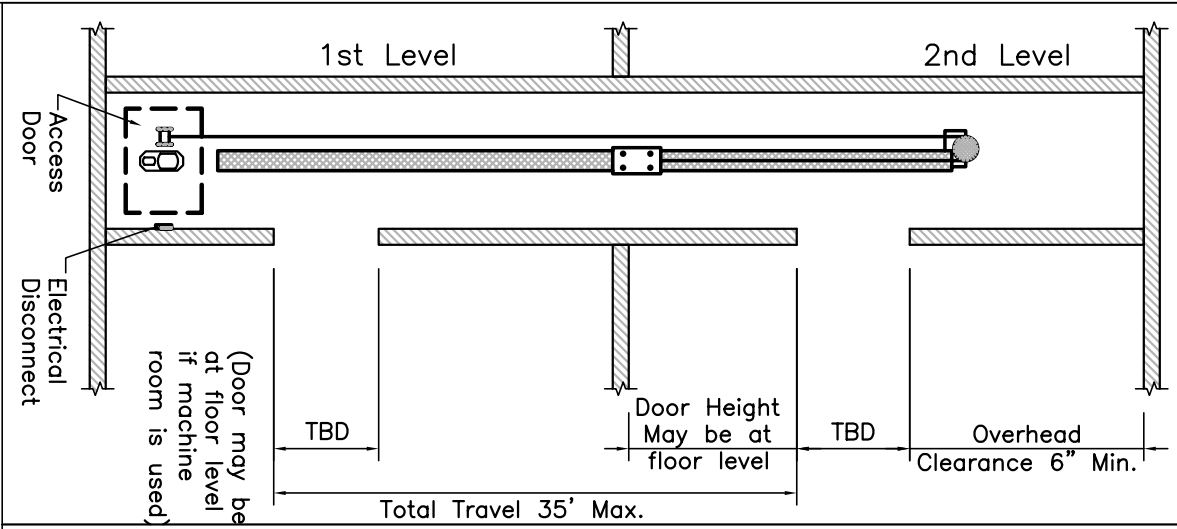
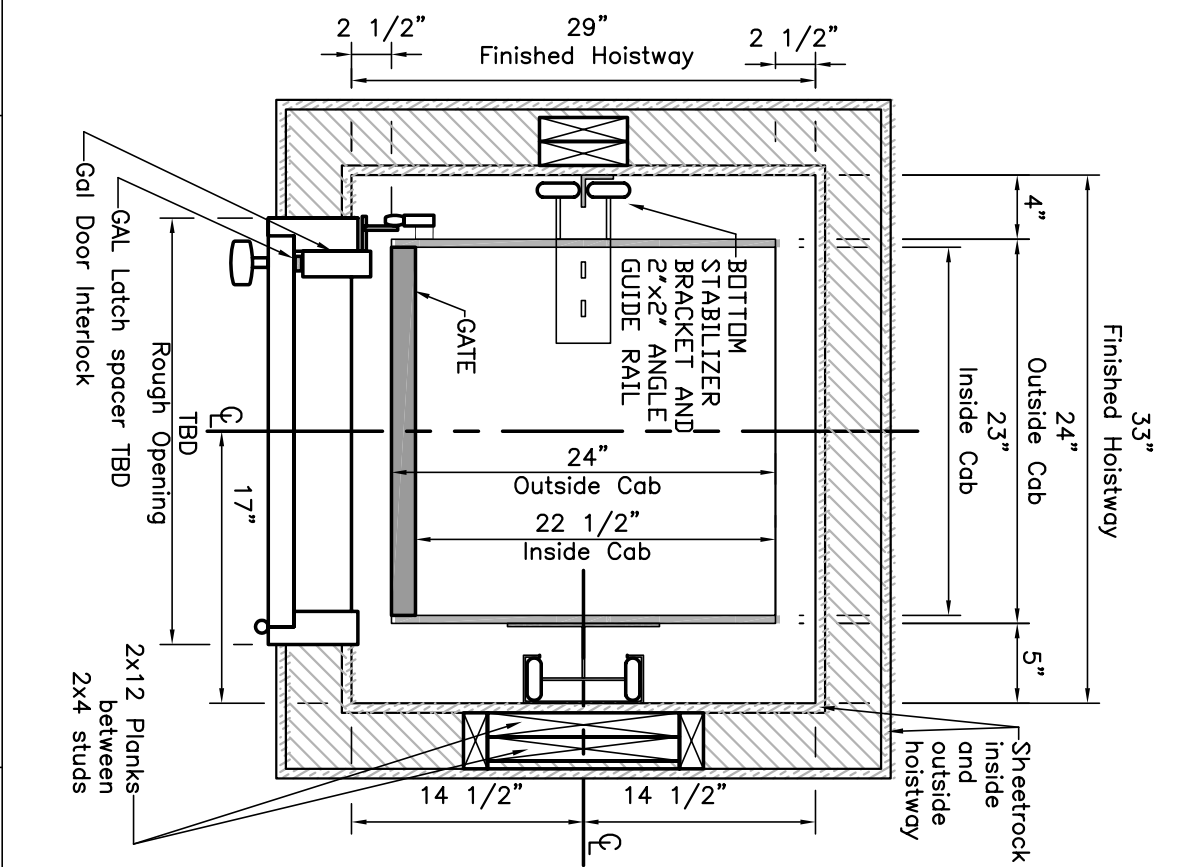

HOISTWAY: THE HOISTWAY MUST BE IN ACCORDANCE WITH "SAFETY CODE FOR ELEVATORS AND ESCALATORS" (ASME A17.1) AND ALL STATE AND LOCAL CODES.

PLUMB HOISTWAY: DUE TO CLOSE RUNNING CLEARANCES OWNER/AGENT MUST ENSURE THAT HOISTWAY IS PLUMB, AND SQUARE AND IS IN ACCORDANCE WITH DIMENSIONS ON THESE DRAWINGS.

REINFORCED WALL: THE RAIL WALL MUST BE REINFORCED WITH DOUBLE 2X12 PLANKS AS SHOWN ON THE DRAWINGS. THE MACHINE AND RAIL SYSTEM REQUIRES THESE 2X12 PLANKS FOR SUPPORT.

MACHINE ROOM: MACHINE ROOM MAY BE LOCATED WITHIN THE HOISTWAY ON THE BOTTOM FLOOR OR IN A CLOSET ADJACENT TO THE HOISTWAY (BEHIND THE RAIL WALL). THE MACHINE ROOM MUST HAVE A LOCKABLE ACCESS DOOR. THIS DOOR MUST REMAINED LOCKED AT ALL TIMES.

CUSTOMER: _____

SHIP TO: _____

APPROVED BY: _____

OPENING: _____

SAME SIDE

DWG NO. _____

JOB NAME: _____

DATE APPROVED: _____

SHEET

1 OF 1

DATE: 10/26/09